



## UHF BASE STATION GROUND PLANE ANTENNA MODEL : UH-2401

### Specifications

GAIN	6.5 dB
VSWR	Less than 1.5:1
FREQUENCY RANGE	430 -490 MHz (70 cm)
POLARIZATION	Vertical
IMPEDANCE	50 Ohm
POWER CAPACITY	200 Watts
CONNECTOR	SO-239

### Assembly

1. Refer to the drawing (rear side of this instruction ).
2. Put the locking nut and washer onto the ground plane radials, then screw the three radials(part #2) into threaded holes on the metal antenna base(part #3) and tighten them by fingers. Secure the radials by tightening locking nuts with wrench.
3. Secure supporting pipe (part #7) to mounting pole (not included) in desired location using brackets (part #9), U-bolts (part #8), locking screws (part #4), locking washers (part #5), and locking nuts(part #6) supplied. Tighten them securely with a wrench or screw driver .
4. Run up the cable from radio through supporting pipe (part #7) and screw PL-259 on cable end tightly onto SO-239 connector at the bottom of antenna. Assemble antenna into support pipe with open threaded hole turned so that it will align with hole on support pipe for locking screw. Screw the locking screw (part #4) into hole and tighten it securely with wrench or screw driver .

### Adjustment

UH-2401 works well on any frequency between 430 – 490 MHz by radiator element cut-tuning. Please refer to the drawing on the rear side of this instruction sheet.

Unfasten the locking screw on the metal antenna base(part #3) of UH-2401. Pull SO-239 connector out and slide the radiator element off the outer tube carefully. Unfasten the screws on the radiator with a screw driver. Cut the L1/L2/L3 to proper length according to the cutting chart. Then assemble three parts of radiator elements and fasten screw with a screw driver. Slide the radiator back into the outer tube and push SO-239 to proper position then fasten the locking screw with a wrench (part #10).

Now you can follow above " Assembly step 1 to step 4 " to install UH-2401.

# UH-2401 UHF BASE STATION ANTENNA

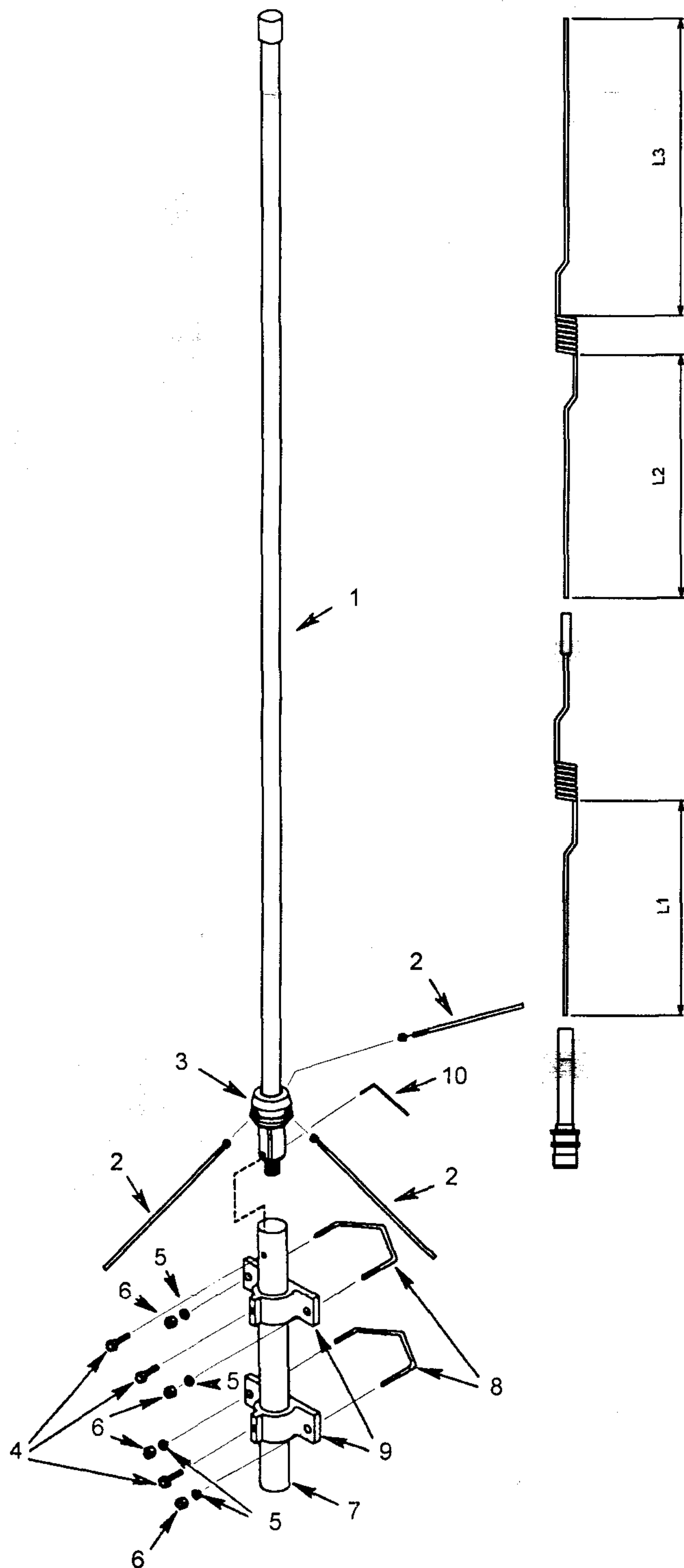

## CUTTING CHART

Freq. ( MHz )	L1		L2		L3	
	mm	inch	mm	inch	mm	inch
430	445	17.51	340	13.39	395	15.55
434	435	17.12	335	13.19	390	15.35
439	425	16.73	330	12.99	385	15.15
442	410	16.14	325	12.79	380	14.96
444	385	15.15	320	12.59	375	14.76
448	370	14.56	315	12.4	370	14.55
452	360	14.17	310	12.2	365	14.37
457	350	13.77	305	12	360	14.17
461	340	13.38	298	11.73	355	13.97
468	325	12.79	290	11.41	350	13.77
473	315	12.4	282	11.1	345	13.58
478	305	12	274	10.78	340	13.38
487	295	11.61	266	10.47	335	13.18
491	285	11.22	257	10.11	330	12.99

## PARTS LIST

NO	DESCRIPTION	Q'TY
1	OUTER TUBE	1
2	RADIALS & NUT, SPRING WASHER	3
3	MAST	1
4	LOCKING SCREW	3
5	LOCKING WASHER	4
6	NUT	4
7	SUPPORTING PIPE	1
8	U-BOLT	2
9	BRACKET	2
10	WRENCH	1

MADE IN TAIWAN